

# THE DALEK

**BUILD  
THE ICONIC  
BBC**



**MONSTER**



**INVADERS  
OF EARTH!**

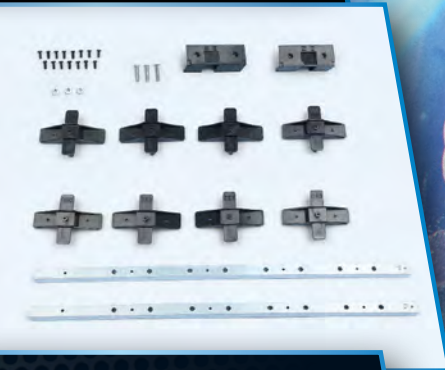

**STEP-BY-STEP  
INSTRUCTIONS**

Published  
weekly • £11.99  
AUS • \$23.99

76 >



9 772977 557054

# DALEK

## ISSUE 76

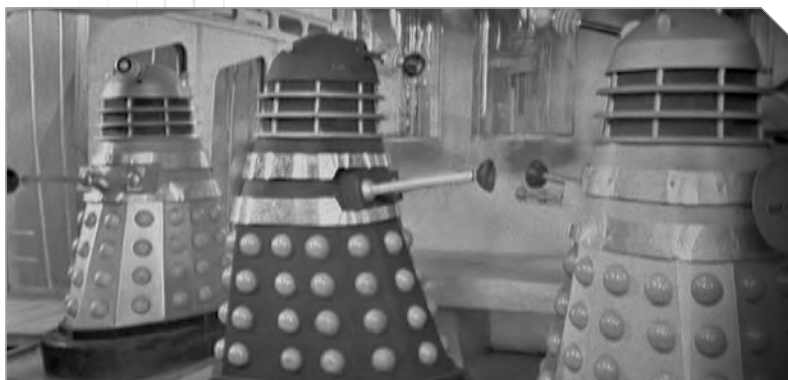

### ADVENTURES IN TIME AND SPACE: DAY OF RECKONING

3

The rebels are defeated and the Daleks plan to destroy London.



### THE TIME VORTEX: ENEMIES OF THE DALEKS: HUMANS

6

The Daleks have fought humanity throughout human history.

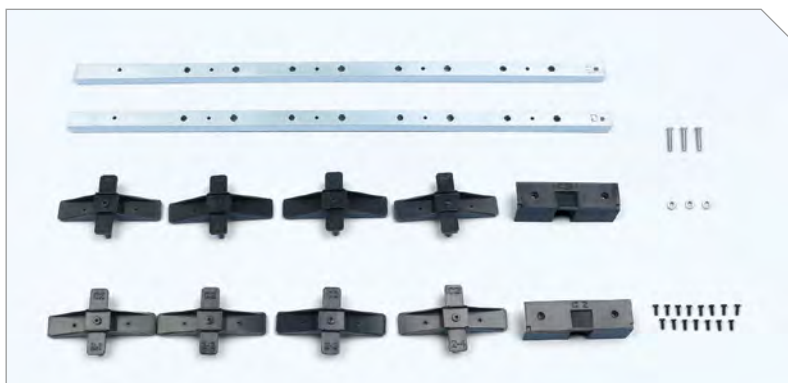

### STEP-BY-STEP BUILD: PART 76

10

Two side supports, some skirt fixings and joints, plus nuts and bolts

## Reader Services

CUSTOMER SERVICE IN THE UK  
AND REPUBLIC OF IRELAND

### How to continue your collection:

Subscribe online at [hachettepartworks.com/Dalek](http://hachettepartworks.com/Dalek) or contact the Customer Service team via [hachettepartworks.com/contact](http://hachettepartworks.com/contact)

### Customer service & back orders:

Please visit [hachettepartworks.com/contact](http://hachettepartworks.com/contact) to get in touch.

UK call 0345 155 9277

ROI call (01) 9079762

(Calls are charged at your local rate from a landline)

Published by Hachette Partworks Ltd  
4th Floor, Jordan House, 47 Brunswick Place, London N1 6EB

General Manager – Isabelle Couderc

Editorial Director – Helen Nally

Marketing Director – Elise Windmill

Production Director – Sema Sant Anna

Managing Editor – Sarah Gale

Distribution Manager – Paul Smith

Product Manager – Rhys Myner

Packaged by Panini Publishing, a division of Panini UK Limited.

Publishing Director Europe – Marco M. Lupoi

Managing Director – Chris Clover

Managing Editor – Alan O'Keefe

Senior Editor – Karen O'Brien

Editor – John Ainsworth

Designer – Barry Spiers

Features Writer – Stuart Ashley

Distributed in the UK and Republic of Ireland by Marketforce.

© 2026 Hachette Partworks Ltd

Printed in the UK.

ISSN 2977-5574

ALL RIGHTS RESERVED

The editor's policy is to use papers that are natural, renewable and recyclable products and made from wood grown in sustainable forests. The logging and manufacturing processes are expected to conform to the environmental regulations of the country of origin.

In the event of a significant increase in production and transport costs, the publisher reserves the right to modify its selling prices.

BBC, DOCTOR WHO, TARDIS and DALEK (word marks and devices) are trade marks of the British Broadcasting Corporation and are used under licence. BBC logo © BBC 1996. DOCTOR WHO logo © BBC 1973. Dalek image © BBC/Terry Nation 1963. Licensed by BBC Studios.

The device complies with Part 15 of the FCC Rules. Operation is subject to the following two conditions: (1) this device may not cause harmful interference, and (2) this device must accept any interference received, including interference that may cause undesired operation.

All parts belong to a kit. NOT SUITABLE FOR CHILDREN UNDER THE AGE OF 14. This product is not a toy and is not intended for use in play. Follow the instructions in the enclosed magazines carefully and keep the appropriate information in a safe place. The installation of the electrical and electronic parts must always be carried out by an adult. Requires batteries.

BBC



For our environmental policy in full please scan the QR code here.

hachette  
PARTWORKS LTD

# DAY OF RECKONING

**The attack on the saucer fails and the Doctor and the rebels must flee London.**

**Season 2 Episode 6  
First Broadcast:  
5 December 1964**

**T** Tyler and the other rebels run inside the saucer and look for prisoners. They don't notice the unconscious Doctor on the operating table. "Commence the operation," a Dalek tells a Roboman. The Dalek leaves the Doctor with the Roboman. Tyler and a resistance fighter named Larry Madison overcome him and rescue the Doctor. The fighters battle to free the prisoners.

Outside the saucer, David tells Jenny to take Barbara and Susan back to the resistance base. "I'm going to help Tyler get them out," he says. Realising that the Doctor and Ian are aboard the saucer, Barbara goes with David. Jenny drags Susan away. Tyler and his men escape the saucer, but Dortmun's bombs are useless against the Daleks.

Ian races out of the saucer, obscured by smoke. Barbara almost throws a bomb at him before seeing him. Ian is forced to go back into the saucer when a Dalek passes by. He hides beneath a hatch in the floor and listens as the Supreme Dalek gives an order: "Find every survivor! Destroy everyone! Destroy them!"

Jenny brings Barbara back to the almost empty resistance base. Dortmun sits silently in his wheelchair. Tyler returns, exhausted by the ordeal. "Your bombs were useless, Dortmun," he says. "How



Barbara asks Dortmun if they might find her friends at the museum. "Yes, it's a possibility," Dortmun replies.

"Supreme Command have given orders for London to be destroyed by firebombs," the Supreme Dalek states. He then gives the order for the saucer to head to the mine workings in central England. The saucer lifts off and heads out of London.

Ian cautiously slides the hatch open and crawls out. He finds Craddock, now transformed into a Roboman, carrying Larry. "You are to be robotised," Craddock says in a monotone. Ian and Craddock fight. Larry helps Ian. Craddock is pushed into some machinery. There is a crackle of energy, and he falls to the floor, dead.

Larry tells Ian that he deliberately came aboard the Dalek ship. "The saucer's going to the mine workings in Bedfordshire," he explains, "and my brother's there. I'm going to find him." They push Craddock's body down a disposal chute. They hear a Dalek announce that a fault has been detected in a Roboman, and hide under the floor.

David and Susan race through the deserted London streets, desperately looking for shelter to avoid detection by the Daleks and Robomen. They hide from a Dalek on patrol. In the distance, they hear a man cry out in anguish before being killed by a Dalek. Susan weeps and buries her head in David's arms. "If only we could go to the ship and get away from here!" she says. David tells her that he couldn't leave. "Things aren't made



better by running away," he says. "Well, it's suicide to stay here!" Susan argues. David responds angrily: "This is my planet! I just can't run off and see what it's like on Venus!" Susan considers his words. "I never felt there was any time or place that I belonged to. I've never had any real identity," she says. David looks at her. "One day you will," he says softly.

Another resistance fighter, Baker, appears, carrying the Doctor, who is barely conscious. Susan is relieved to see her grandfather. Baker tells David that only a handful of people got away. He says that he's going to make for the Cornish coast. David gives him a hip flask for his journey and wishes him luck. Baker moves down an alley and runs into two Daleks. He is killed instantly.

many men were killed?" Dortmun asks. "I think all of them," Tyler replies. He says that they have to leave London. Dortmun says that he must stay and work on his bomb. Tyler leaves, despite Barbara's pleas for them to stay together. Dortmun says that they must go to the resistance's second base at the Civic Transport Museum so he can continue his work. "It'll mean going over one of the bridges and across London," he tells Barbara. She says that she and Jenny will go with him. Jenny coldly states that they'd have a better chance without Dortmun.



## LOCATION FILMING



Jacqueline Hill recalled the outdoor filming for the story: "Shooting *The Dalek Invasion of Earth* on location was hardly what you'd call a massive amount of location filming, and the location itself was just around the corner from where we recorded in the studios in Hammersmith. We had

very little time to do it in, more or less one take only, so it was just as bad as working inside. I can recall very clearly filming the sequences in and around the famous landmarks of London, because we shot them first thing in the morning, as soon as the light came up – on a Sunday too! That was even more arduous because we had to run along pushing this wheelchair, which, I can tell you, soon lost its novelty value."

## DALEK GRUDGE

"We cast the Dalek operators because they were small and muscular," director Richard Martin said. "One of them was called Bob Jewell, who's now a weightlifter or something in Australia, and he absolutely hated me. The funniest





As dawn breaks, Barbara and Jenny push Dortmund in his wheelchair along the side of the Thames. The trio avoid a squad of Daleks and race across Westminster Bridge undetected. They hide from Daleks patrolling Trafalgar Square and the Albert Memorial, eventually reaching the transport museum. Dortmund resumes work on improving his bomb and soon declares it finished. "The problem, you see, was the metal the Daleks use in their outer casing," he says to Barbara. "We don't know very much about it. We call it Dalekanium." Barbara wonders if the Daleks could be mining for Dalekanium in Bedfordshire, but Dortmund points out that they must have had it before they invaded Earth. Whatever the Daleks want, it must only be found deep inside Earth.



Jenny returns from a fruitless search for other fighters. Barbara feels certain that the Doctor will be heading for the mine. "If he's alive," Jenny remarks bluntly, "what's so special about the Doctor? He doesn't wear some sort of invisible shield, does he?" Barbara goes silent. Dortmund asks Jenny to go outside and stand watch. "She's not callous, really, you know," he says to Barbara. "People have to fight the Daleks in their own way." Dortmund asks Barbara to give the Doctor his notes on his bomb when she finds him. Barbara refuses to leave Dortmund behind and goes to collect Jenny. Dortmund puts his notes on the table and wheels himself outside. Barbara and Jenny return to find him gone. Seeing his notes, Barbara realises that Dortmund intends to test the bomb himself.

"Daleks!" Dortmund yells outside, attracting the attention of three of the invaders. He slowly stands. The Daleks fire at him as he throws his bomb. Dortmund is dead before he hits the ground. The bomb does not work.

Susan helps the Doctor exercise his legs. The old man slumps to the ground, still very tired from their experiences. Susan says that they should travel north with David and join up with other resistance fighters, but the Doctor thinks they should return to the TARDIS. He is annoyed to find Susan questioning his authority. David returns from a scouting trip and, to the Doctor's surprise, asks for his advice. The Doctor suggests that they travel north and try to join up with the resistance party. "It's a very good idea, grandfather," Susan says, smiling.

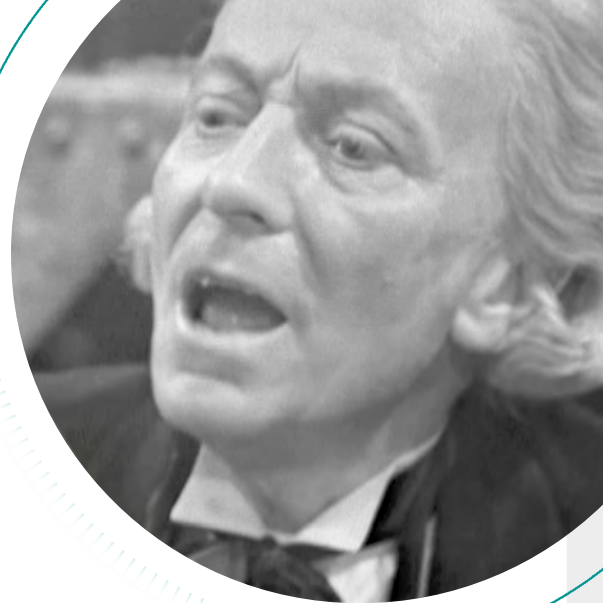

The Dalek saucer lands in Bedfordshire. Larry tells Ian that his brother Phil has a theory: the Daleks want the magnetic core of Earth. They wait for the Daleks, Robomen, and prisoners to disembark, then climb out of the hatch and leave through the disposal chute.

Back in London, two Robomen carry a large device to a point near the Doctor, Susan, and David. They place it on the ground and leave. The device has a timing mechanism with a dial on its face. It begins to tick. The arrow on the dial moves, counting down to detonation...



thing I read in a *Doctor Who* magazine I was sent was an interview with him, where he said, 'Bloody silly director. They were working perfectly well and he wanted to put them on these bloody big wheels, and they were very dangerous!' This was because we wanted the shot which later became quite famous of the Daleks coming across Westminster Bridge. They had to come across at a hell of a whack. We started about two o'clock in the morning on a Sunday and the police said we had to be out of Central London by six. So, we were sitting there waiting for the dawn, and we did it as a running thing: Trafalgar Square, a couple of Daleks snooping around the Cenotaph, then they went whacking across Westminster Bridge with the Houses of Parliament in the background. By this time the first buses were coming, and we were having to work around them, but Bob Jewell wouldn't go fast enough for us. I was giving him a hard time, pressing for faster, faster, faster. 'No, it's not safe, I'm not going to...' he'd say. Not safe! Rubbish! Get it done! He was pedalling like fury, and of course, he bore me an enormous grudge. He let off steam splendidly in that magazine!"

## ANN DAVIES



Jenny was played by Ann Davies. In the initial scripts, the character was called Saida and was described as a 'beautiful Anglo-Indian girl'. After Dortmund's death, Saida would reveal that he was her father. With Carole

Ann Ford wishing to leave the series, the plan was to have Saida hide in the TARDIS at the end of the story and join the regular characters as Susan's replacement. This idea was eventually abandoned. In the location scenes, Davies wore a balaclava to hide her dark hair. She would later dye her hair blonde for the studio recordings to create a better visual contrast with Carole Ann Ford.

# ENEMIES OF THE DALEKS: HUMANS

**D**aleks and humans have fought endless battles across the centuries, on Earth and across the stars. Here are some of their most critical conflicts...

## RESOLUTION

One of the earliest recorded encounters between Daleks and humans took place on Earth in the ninth century. Unsurprisingly, they met in battle. A single Dalek Reconnaissance Scout was part of a taskforce searching for worlds that could be exploited and conquered. The Scout encountered heavy resistance from several human tribes. It killed hundreds of warriors until the tribes banded together and devised a plan to destroy it in the

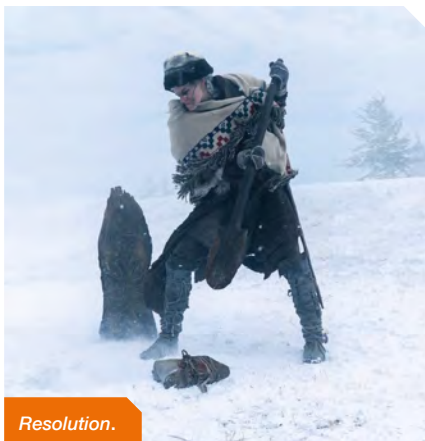

Resolution.

legendary Battle of Hope Valley. They applied intense heat to the Dalek's casing, weakening it long enough to break it open and attack the Dalek mutant inside. The mutant's remains were split into three sections. The mutant managed to briefly reassemble itself in England in 2019

## THE DALEK INVASION OF EARTH

The Daleks conquered Earth in the 22nd century after waging a secret, prolonged assault using a plague virus and a directed meteor shower. The Daleks were few in number and relied on controlled humans called Robomen as their police force. Humanity continued to resist the occupation despite the Daleks' ruthless acts of suppression. The Daleks intended to remove the magnetic core of Earth and replace it with a device of their own design, enabling them to pilot Earth as a gigantic spacecraft. They were defeated by the Doctor and Earth's resistance fighters.

## DAY OF THE DALEKS

The Daleks travelled into their own history and again struck at Earth in the 22nd century. This time, they used alien mercenaries called Ogrons to police humanity. Some humans also willingly collaborated with the Daleks. However,

the human resistance was once again well organised: guerillas stole Dalek time-travel devices and travelled back to Earth in the 20th century to prevent the outbreak of a global war. With the help of the Doctor, they erased the divergent Dalek timeline.

## THE POWER OF THE DALEKS

Three Daleks were discovered in a swamp on the Earth colony Vulcan in an undated future era. Humanity had no historical records of the Daleks in this time period, and the aliens were believed to be mere service robots. Surrounded and outnumbered, the Daleks allowed the humans to believe they were harmless functionaries while they

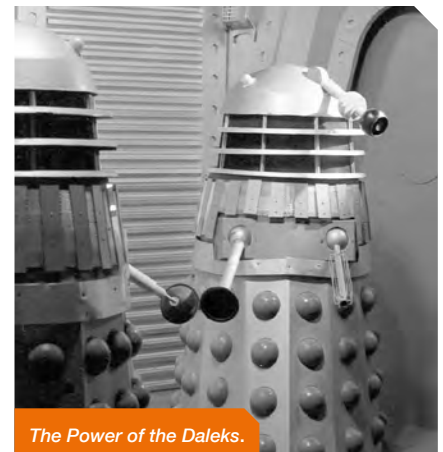

The Power of the Daleks.



Remembrance of the Daleks.

gathered their resources. The Daleks realised that a secret power struggle was taking place among the colonists and took advantage of it to manipulate them. The Doctor intervened and drained them of their energy source.

### THE EVIL OF THE DALEKS

The Daleks' growing interest in humanity was revealed to the Doctor when he and his companion, Jamie McCrimmon, were kidnapped by them and brought to the year 1866. The Daleks had noted that humanity had defeated them far more often than any other species. The Emperor Dalek decided that a greater understanding of their enemies would benefit them. The Daleks forced the Doctor to set a series of tasks for Jamie while recording his emotional responses. This was an attempt to quantify what they called the 'Human Factor'. Bravery, compassion, ingenuity, imagination, and curiosity were the strongest elements to be registered. The discovery of the Human Factor also allowed them to isolate the Dalek Factor: the fundamental traits of all Daleks. The Emperor Dalek planned to target humanity by spreading the Dalek Factor throughout Earth's history, turning all humans into mindless slaves. The Doctor used the Human Factor against them and initiated a Dalek civil war on Skaro.

### REMEMBRANCE OF THE DALEKS

A small team of renegade Daleks travelled back in time to Earth in 1963 in search of the Time Lord artefact called the Hand of Omega. The leader of the renegades had a detailed understanding of humanity and knew the type of personality that could be most easily recruited to the Dalek cause. It chose

George Ratcliffe, a racist political agitator who had been imprisoned for supporting the Nazis during World War II. The Daleks used Ratcliffe's men as their servants but faced opposition from the British Army. They were ultimately outwitted by the Doctor.

### THE DALEKS' MASTER PLAN

In the 41st century, Daleks and humans had reached an uneasy stand-off. The Terran Empire had spread across the Milky Way galaxy, while the Daleks turned their attention to the outer galaxies. They avoided contact with humanity for nearly a century. The impasse was only broken with the appearance of Mavic Chen, the Guardian of the Solar System. Chen was an arrogant narcissist who held no allegiance to his own species. He reached out to the Daleks with a plan to betray his own people. For the first

time, the Daleks formed alliances with other species in an attempt to destroy humanity – an act that would previously have been unthinkable. The Doctor, allied with agents of Earth's Space Security Service, defeated Chen and the Daleks.

### THE STOLEN EARTH

The Daleks' plan to create the Reality Bomb brought them into conflict with humanity once more. The Daleks were supremely confident of victory – they had reached the height of their power and time-travelled back to the early 21st century to attack Earth. The Daleks announced their approach by repeatedly chanting "Exterminate!" over every wavelength to instil terror in their enemies. Humanity's most advanced vessel, the airship known as the *Valiant*, was swiftly destroyed by a squadron of Daleks. Groups of humans were captured and used as test subjects for the Reality Bomb. There is no doubt that the Daleks chose Earth as one of the 27 planets needed to power the Reality Bomb because of the hatred they had developed for humanity over the centuries. In the end, however, it was a human, Donna Noble, who brought about their defeat.

While the Time Lords are the most powerful enemy the Daleks have ever faced, it is possible that the Daleks perceive humanity as their most tenacious foe. Humans seem to be the only species that can match the Daleks in ingenuity in warfare. Perhaps the Daleks harbour a grudging respect for their opponents from Earth.



The Stolen Earth.

# BASE SECTION

## INTERNAL SUPPORT STRUCTURE

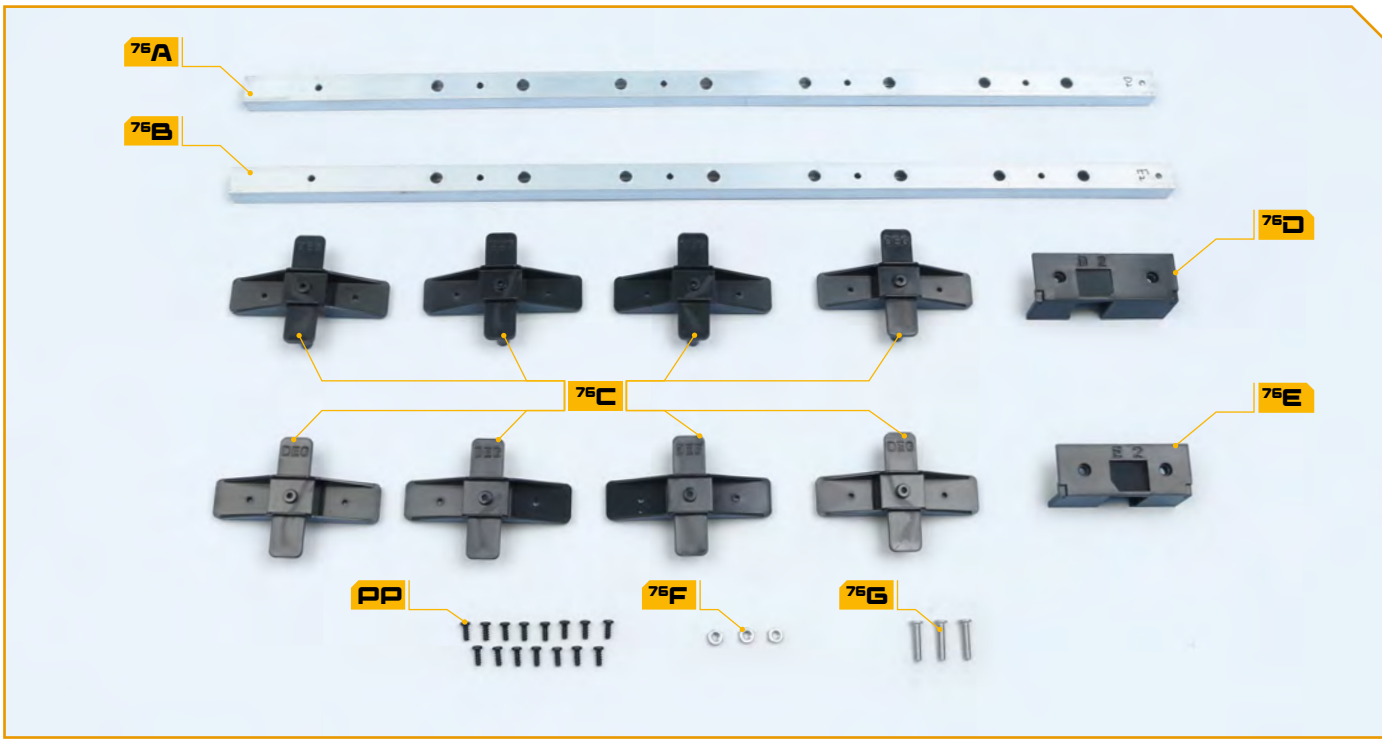

### COMPONENTS OF ISSUE 76

- 76A** SIDE SUPPORT (labelled D1)
- 76B** SIDE SUPPORT (labelled E2)
- 76C** EIGHT SKIRT FIXING PARTS (labelled DEG)
- 76D** SIDE SUPPORT TOP JOINT (labelled D2)
- 76E** SIDE SUPPORT TOP JOINT (labelled E2)
- 76F** NUTS (x 3, 1 spare)
- 76G** BOLTS (x 3, 1 spare)
- PP** FIFTEEN 2.6 X 6MM PB SCREWS (1 spare)

### #76-01

Take the side support **76A** (marked D2) and four of the skirt fixing parts **76C**. Position them as shown, so that the raised screw holes on the skirt fixing parts fit into the large holes in part **76A**. Note that the label **D2** on part **76A** is at the top. Fix each fixing part in place from the back of the side support **76A** with a **PP** screw.

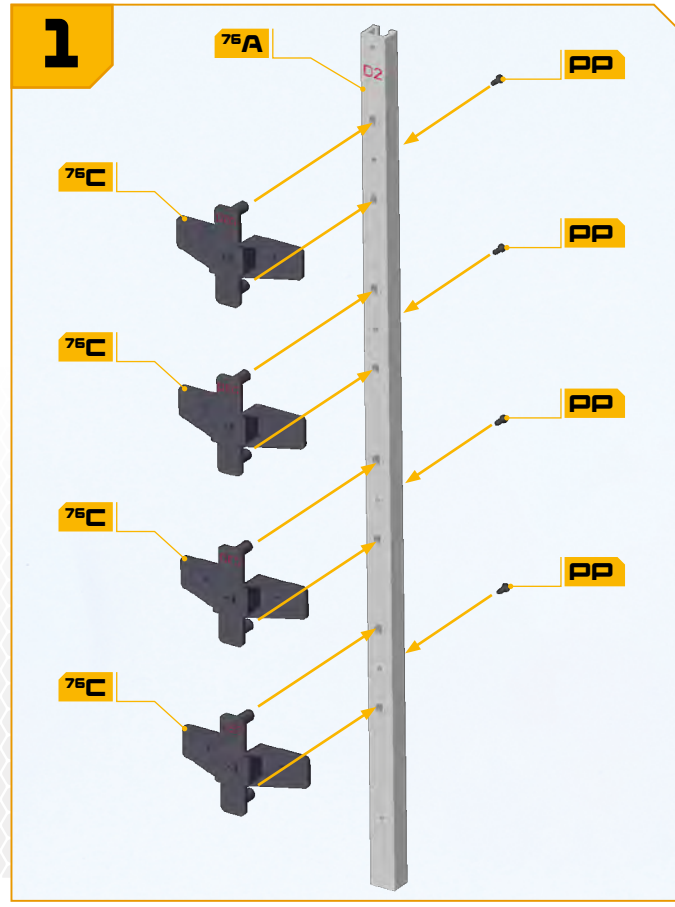

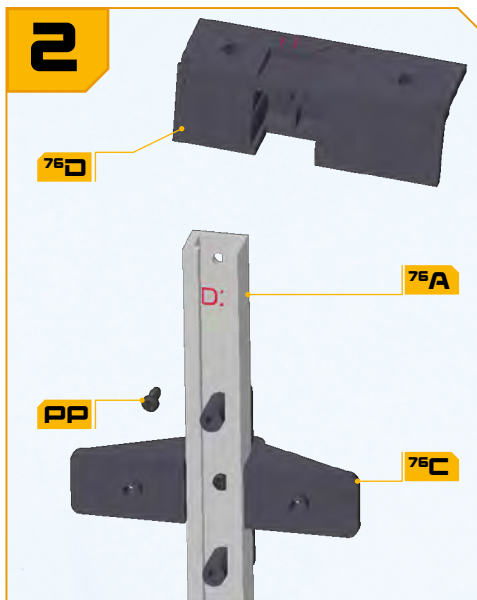

### #76-02

Take the side support top joint (labelled D2) **76D** and fit the top of part **76A** into the recess so that screw holes are aligned. Note the orientation of the parts with the channel in part **76A** and the raised screw sockets in parts **76C** are facing forwards. Fix in place with a **PP** screw.

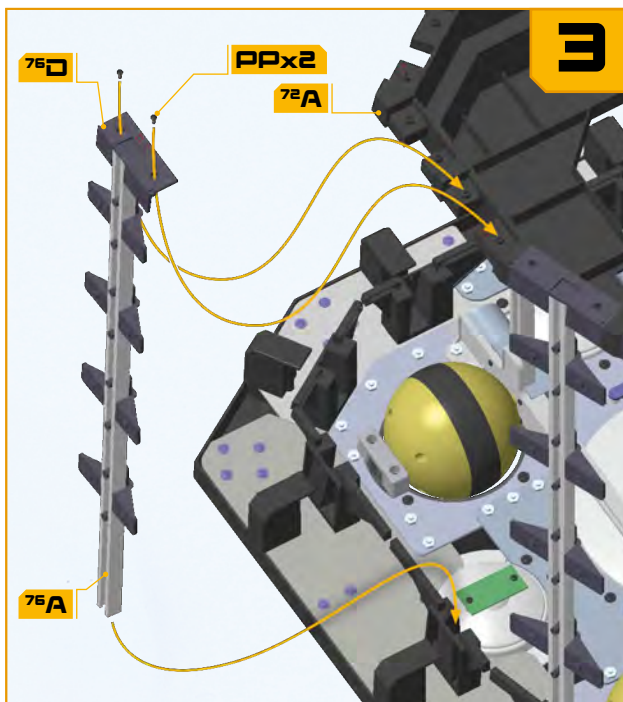

### #76-03

Fit the base of the side support **76A** into the channel in the next skirt support, half way down the right-hand side. Fit the top joint **76D** into the corresponding shape marked **D2** in the side of the chest support **72A**. Fix in place with two **PP** screws (inset).

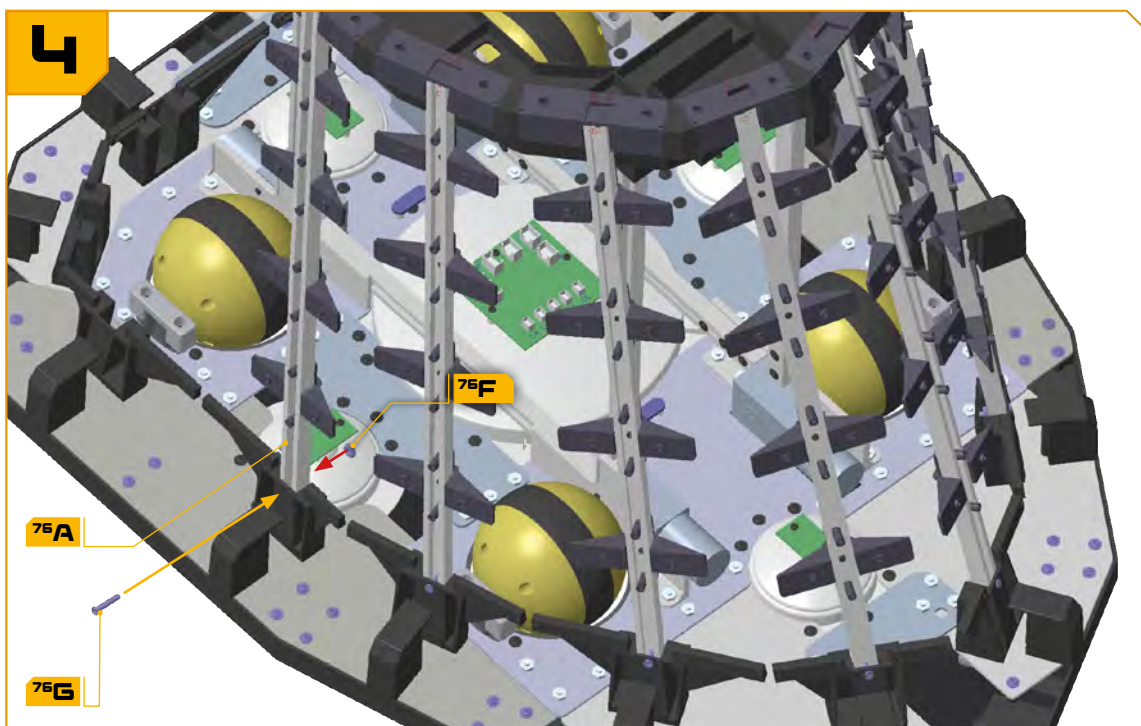
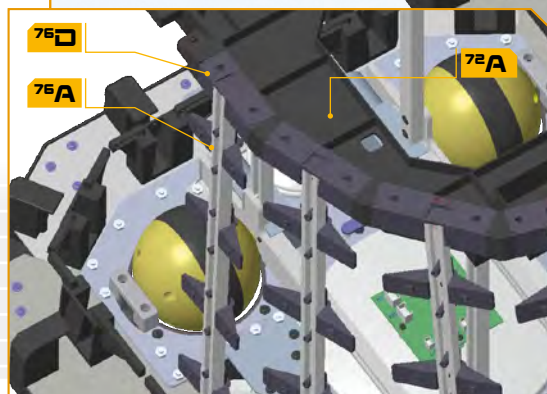

### #76-04

Fit a bolt **76G** through the screw holes in the skirt holder and part **76A** (yellow arrow). Fit a nut **76F** on the end of the bolt to hold it in place (red arrow). Use the spanner **38F** to help tighten the nut if necessary.

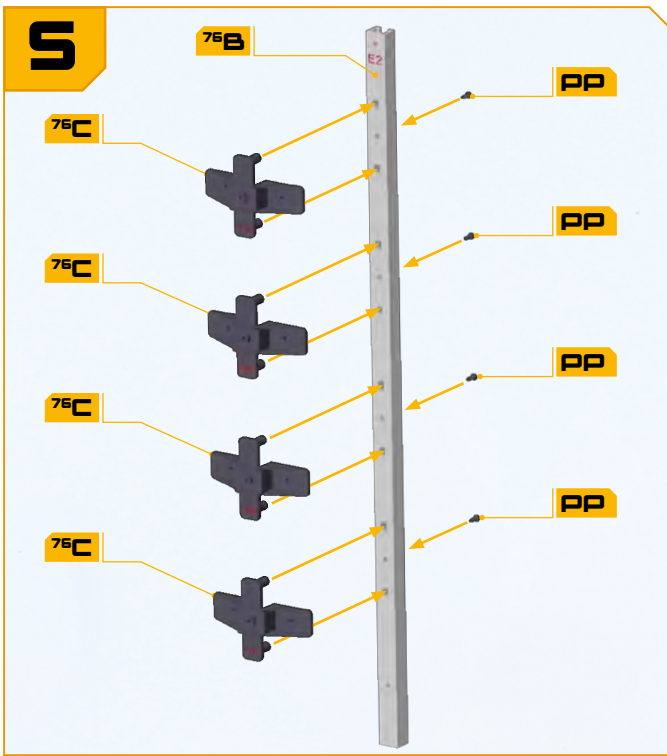

**#76-05**  
 Take the side support **76B** (marked E2) and the remaining four skirt fixing parts **76C**. Position them as shown, so that the raised screw holes on the skirt fixing parts fit into the large holes in part **76B**. Fix each fixing part in place from the back of the side support **76B** with a **PP** screw.

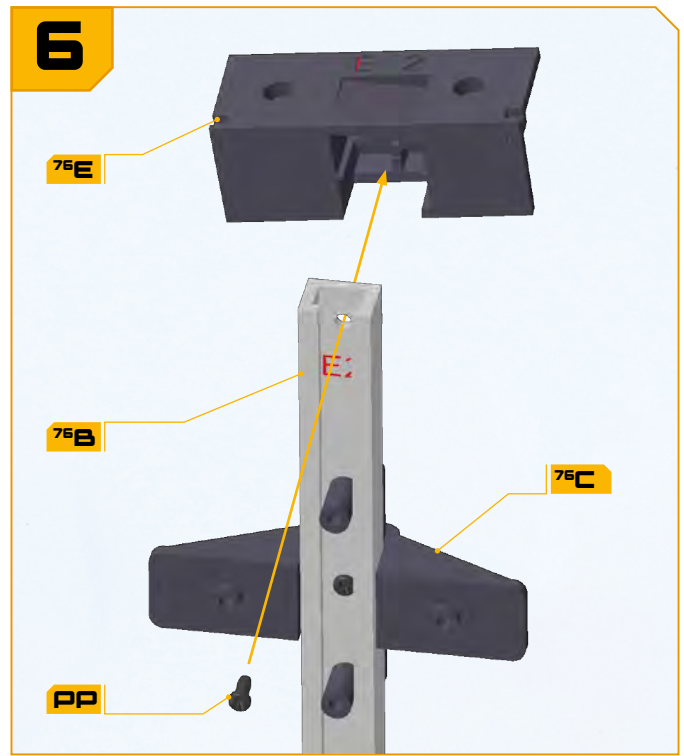

**#76-06**  
 Take the side support top joint (labelled E2) **76E** and fit the top of part **76B** into the recess so that screw holes are aligned. Note the orientation of the parts with the channel in part **76B** and the raised screw sockets in parts **76C** are facing forwards. Fix in place with a **PP** screw.

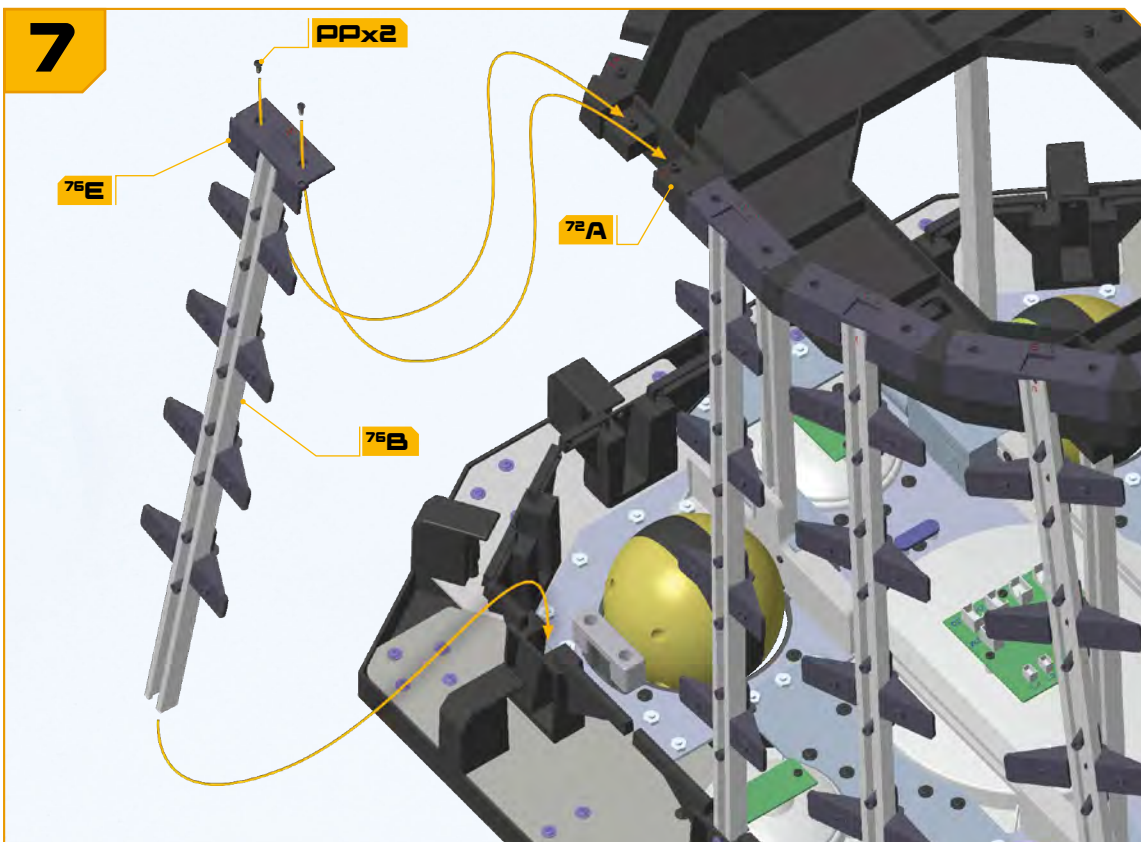

**#76-07**  
 Fit the base of the side support **76B** into the channel on the inner side of the next skirt support beside the rear right wheel. Fit the top joint **76E** into the corresponding shape in the side of the chest support **72A**, which is marked **E2**. Fix in place with two **PP** screws.

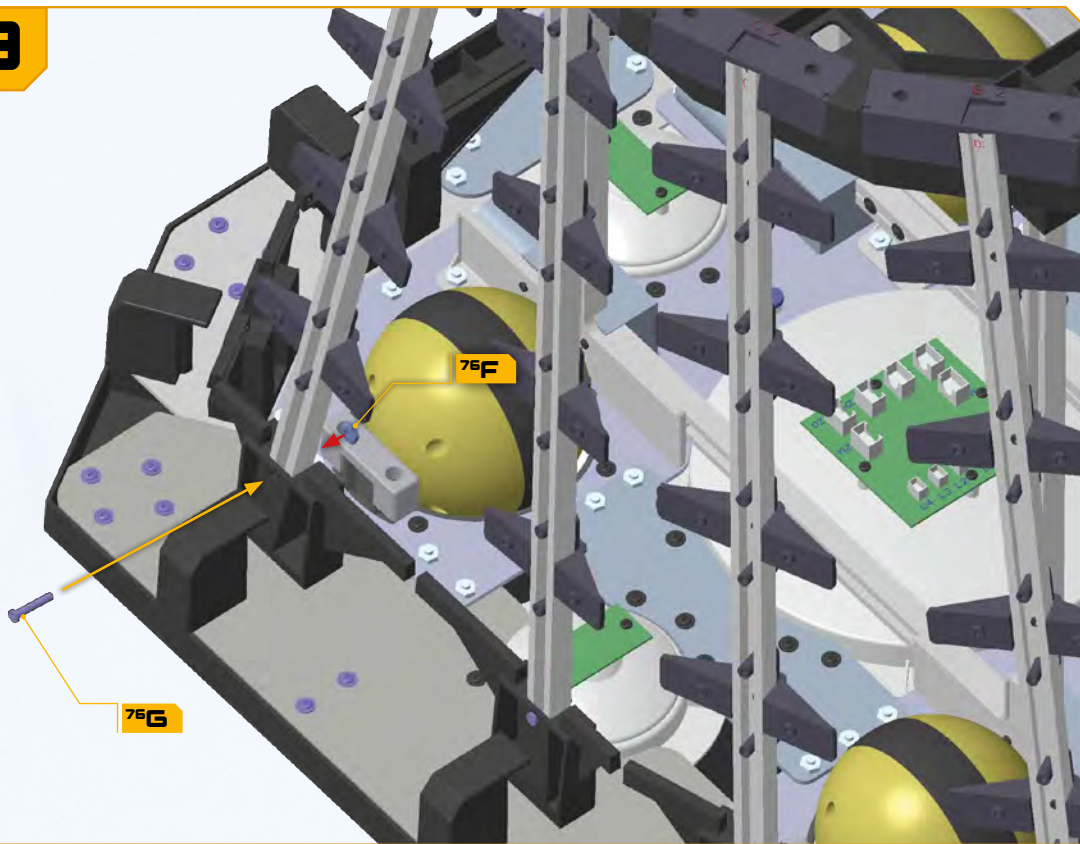
**8****#76-08**

Fit a bolt **76G** through the screw holes in the skirt support and part **76B** (yellow arrow). Fit a nut **76F** on the end of the bolt to hold it in place (red arrow). Use the spanner **38F** to help tighten the nut if necessary.

**COMPLETED WORK****#076 COMPLETED WORK**

Skirt supports have been fitted on the right-hand side of your model. The chest support is still not fully attached, so be careful how you move the model.

# THE DALEK



COMING IN  
ISSUE 77

## BUILD PART 77

Continuing the internal support structure for the skirt section, issue 77 includes further side supports, skirt fixings, joints and all the required nuts and bolts.

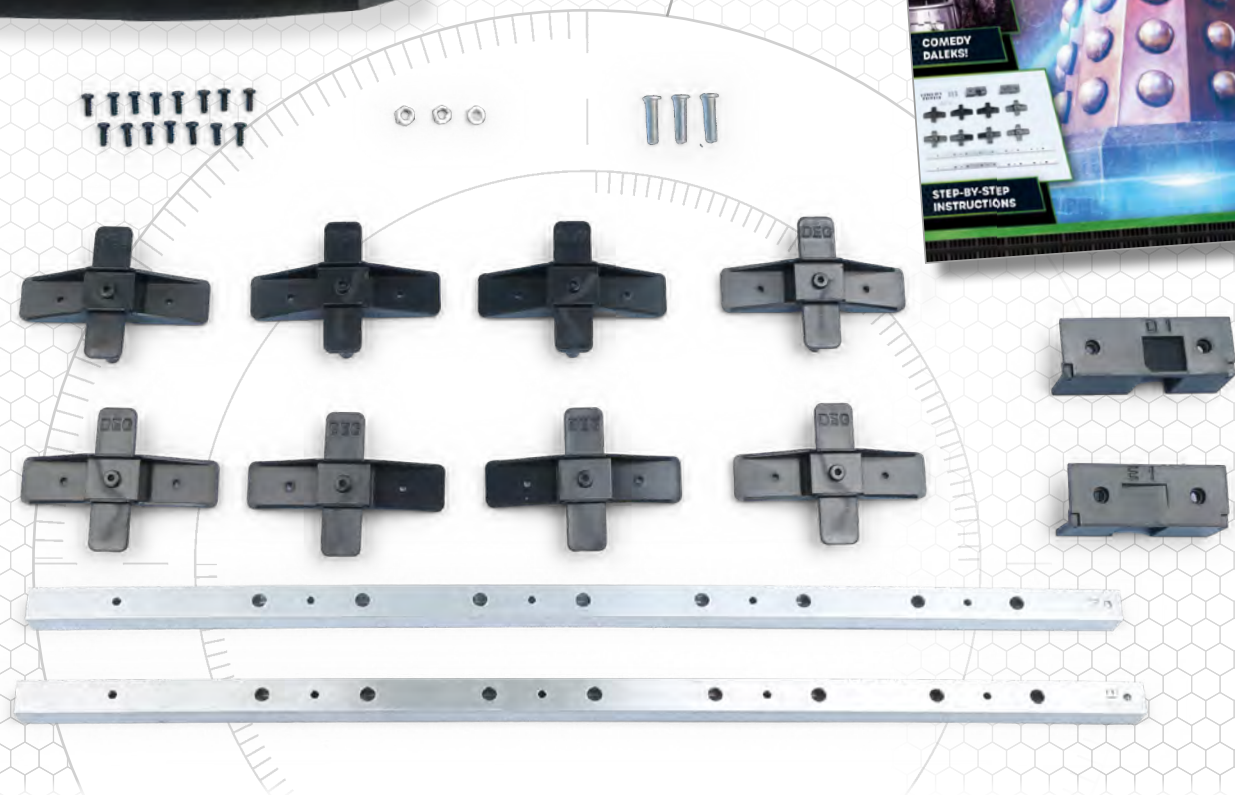

### BEHIND THE SCENES



The Daleks were featured in the special comedy *Doctor Who* episode, *The Curse of Fatal Death*, for 1999's Comic Relief.

### ADVENTURES IN TIME AND SPACE



In 1815, the Doctor sees Davros in a new light when he and his old enemy swap bodies in *The Curse of Davros*.

Every week at your newsagent! Visit [hachettepartworks.com/Dalek](http://hachettepartworks.com/Dalek)