

# THE DALEK

**BUILD  
THE ICONIC  
BBC**



**MONSTER**



**DAVROS  
SURVIVES!**

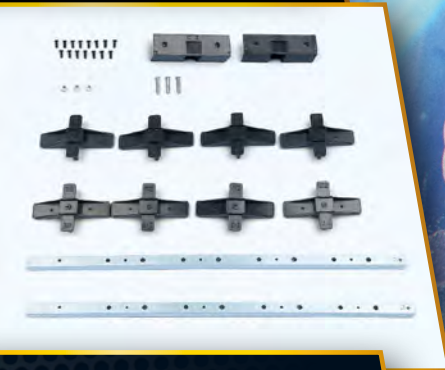

**STEP-BY-STEP  
INSTRUCTIONS**

Published  
weekly • £11.99  
AUS • \$23.99

75 >



9 772977 557054

# DALEK

## ISSUE 75



### ADVENTURES IN TIME AND SPACE: THE MAGICIAN'S APPRENTICE

3

An ailing Davros summons the Doctor to Skaro.



### THE TIME VORTEX: DAVROS - PART 7

6

On the planet Necros, Davros sets a trap for the Doctor.

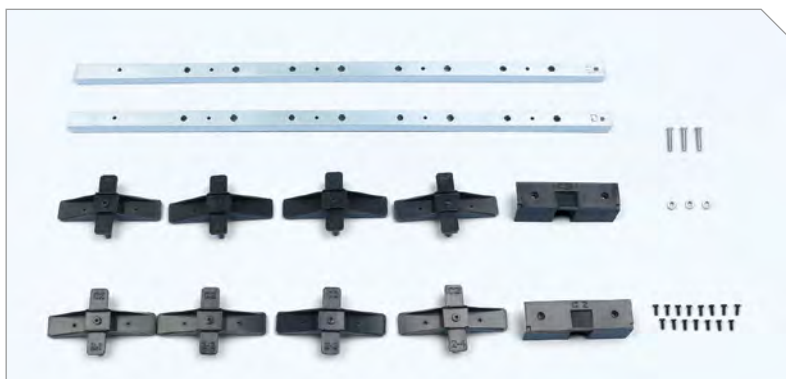

### STEP-BY-STEP BUILD: PART 75

10

Side supports, skirt fixings and the necessary joints and screws.

## Reader Services

CUSTOMER SERVICE IN THE UK  
AND REPUBLIC OF IRELAND

### How to continue your collection:

Subscribe online at [hachettepartworks.com/Dalek](http://hachettepartworks.com/Dalek) or contact the Customer Service team via [hachettepartworks.com/contact](http://hachettepartworks.com/contact)

### Customer service & back orders:

Please visit [hachettepartworks.com/contact](http://hachettepartworks.com/contact) to get in touch.

UK call 0345 155 9277

ROI call (01) 9079762

(Calls are charged at your local rate from a landline)

Published by Hachette Partworks Ltd  
4th Floor, Jordan House, 47 Brunswick Place, London N1 6EB

General Manager – Isabelle Couderc  
Editorial Director – Helen Nally  
Marketing Director – Elise Windmill  
Production Director – Sema Sant Anna  
Managing Editor – Sarah Gale  
Distribution Manager – Paul Smith  
Product Manager – Rhys Myner

Packaged by Panini Publishing, a division of Panini UK Limited.

Publishing Director Europe – Marco M. Lupoi  
Managing Director – Chris Clover  
Managing Editor – Alan O'Keefe  
Senior Editor – Karen O'Brien  
Editor – John Ainsworth  
Designer – Barry Spiers  
Features Writer – Stuart Ashley

Distributed in the UK and Republic of Ireland by Marketforce.

© 2026 Hachette Partworks Ltd

Printed in the UK.

ISSN 2977-5574

ALL RIGHTS RESERVED

The editor's policy is to use papers that are natural, renewable and recyclable products and made from wood grown in sustainable forests. The logging and manufacturing processes are expected to conform to the environmental regulations of the country of origin.

In the event of a significant increase in production and transport costs, the publisher reserves the right to modify its selling prices.

BBC, DOCTOR WHO, TARDIS and DALEK (word marks and devices) are trade marks of the British Broadcasting Corporation and are used under licence. BBC logo © BBC 1996. DOCTOR WHO logo © BBC 1973. Dalek image © BBC/Terry Nation 1963. Licensed by BBC Studios.

The device complies with Part 15 of the FCC Rules. Operation is subject to the following two conditions: (1) this device may not cause harmful interference, and (2) this device must accept any interference received, including interference that may cause undesired operation.

All parts belong to a kit. NOT SUITABLE FOR CHILDREN UNDER THE AGE OF 14. This product is not a toy and is not intended for use in play. Follow the instructions in the enclosed magazines carefully and keep the appropriate information in a safe place. The installation of the electrical and electronic parts must always be carried out by an adult. Requires batteries.

BBC



For our environmental policy in full please scan the QR code here.

hachette  
PARTWORKS LTD



# THE MAGICIAN'S APPRENTICE

**The dying Davros summons the Doctor to Skaro for one final confrontation.**

**Series 9 Episode 1**  
**First Broadcast:**  
**19 September 2015**

A group of soldiers run across a war-torn, barren landscape. They are strafed by a biplane shooting energy beams. A soldier named Kanzo sees a young boy running into the mist in panic. "Stop running!" he yells. The boy halts. The ground beneath them seems to ripple. Kanzo checks it with a scanner and tells the boy to stay completely still, warning him about the "hand mines". Kanzo looks down and sees a hand emerging from the mud, grasping his boot. He tries to reassure the boy but is suddenly pulled under the ground, meeting his death. Dozens more hands slowly emerge from the ground, each with an eye in its palm. "Help me!" the boy screams.

The sonic screwdriver flies through the air, landing near the boy. The voice of the Doctor calls out, just beyond the field of hand mines. He tells the boy to introduce himself. "Come on... tell me the name of the boy who isn't going to die today!" The boy pauses for a moment. "Davros," he says. The Doctor freezes as he realises that he is speaking to the future creator of the Daleks...

A sinister hooded creature glides into a seedy bar inside the Maldovarium. "We are Colony Sarfff," he says. "Where is

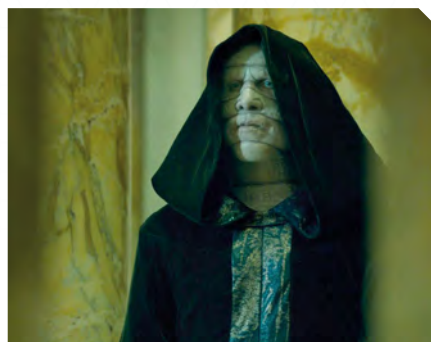

the Doctor?" The patrons remain silent. Sarff's body writhes and twists, and everyone draws back in fear.

Colony Sarff arrives at the headquarters of the Shadow Proclamation. "The Doctor is required," he says. The Shadow Architect stares at him. "What does Davros want with the Doctor?" she asks.

Lightning cracks the sky of Karn, home to the mysterious Sisterhood. Colony Sarff is confronted by Ohila, their leader. "Davros is dying," Sarff says. "Davros is ancient," Ohila retorts. "He should have been dust centuries ago." Sarff replies, "Tell the Doctor... Davros remembers. Tell him he must face Davros one last time..." Once Sarff departs, Ohila turns to the Doctor, who is hidden in the rocks. "Doctor? What have you done?" she asks. He doesn't reply.

Later, in a control room, an exhausted Davros can barely summon the energy to speak to Sarff. Davros is surrounded by a tangle of snake-like cables. He tells his servant to seek out the Doctor's friends.



Clara Oswald is teaching an English class at Coal Hill School when she notices an aeroplane frozen in the sky. She heads to UNIT's base in the Tower of London, where Kate Stewart tells her that every plane in the world is trapped midair. Missy contacts them and summons Clara to Spain. She tells Clara that she can't find the Doctor and shows her a circular device. "It's a Confession Dial," she explains. "The last will and testament of the Time Lord known as the Doctor, to be delivered, according to ancient tradition, to his closest friend on the eve of his final day." Clara tries to pick it up

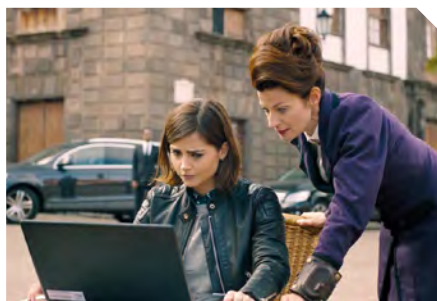

but receives a shock. Missy insists that she, not Clara, is the Doctor's closest friend. When Clara sarcastically asks if Missy has "turned good", Missy kills two UNIT agents. Clara demands that Missy release the planes before she will help her locate the Doctor.

UNIT scans historical records for signs of the Doctor and tracks him to a castle in Essex in 1138. Missy uses a vortex manipulator to transport herself and Clara there. "Face me, magician!" yells a large warrior named Bors in the courtyard. He is surrounded by a baying crowd. The Doctor emerges from the smoke, standing atop a tank and playing an electric guitar. The crowd cheers. The Doctor has been partying in the castle for three weeks. Clara is surprised when he hugs her. Missy enters the courtyard. "It's the wicked stepmother!" the Doctor cries. "Everyone hiss!"

Bors begins to choke. A snake pops out of his mouth and slithers across the ground towards Colony Sarff. "Doctor. Your friends have led me to you," he says. "You will come." Sarff's body separates into dozens of snakes, and the crowd flees in horror. The Doctor demands that he spare the lives of everyone present, and Sarff reassembles himself into humanoid form. The Doctor asks why Davros wants to see him. "Davros knows. Davros remembers," Sarff replies. He throws the sonic screwdriver to the Doctor. Missy studies his expression. "Never seen that before. Doctor, the look on your face... what is that?" she asks. "You're ashamed," Clara replies, worried.



On Skaro, centuries ago, the young Davros calls out for help but hears only a strange wheezing, groaning sound fading away.

The Doctor, Clara, and Missy all accept Colony Sarff's strange invitation and are teleported away. Bors emerges from the shadows and discovers the TARDIS in a cellar. A Dalek eyestalk protrudes from his forehead. "Inform High Command. It is located," he says.

While in flight on Sarff's spaceship, the Doctor tells Clara about his arch-enemy. He is sombre and contemplative: "Davros made the Daleks. But who made Davros?" They arrive at a structure floating in space. The Doctor is taken away by Sarff, while Missy skips around. She points out to Clara that the gravity in



## COLONY SARFF

Actor Jami Reid-Quarrell played Colony Sarff: "I got a call from my agent, and they said, 'Welcome to the Whoniverse!' When I saw the designs of the prosthetics, the excitement stepped up again because I could see how scary this guy could be. What was really nice was that I was part of the process of developing how Sarff moves and speaks. The effects department explored different options for how we could get Sarff to glide around." Reid-Quarrell operated a Segway hoverboard to create Sarff's eerie movement: "When I came in for the first proper FX trial, I got straight on our secret gliding machine, and bang, it just worked straight away! From that point on, it was just [about] getting used to it and making it my own. I made sure I spent a lot of time on it. I took it out in the park without the Sarff prosthetics and the cloak. So, I was floating around on my local tennis courts and getting a lot of looks. A lot of teenagers [were] coming over and saying, 'What is that? How are you doing that?'"



## DAVROS' RETURN

Davros returned from 2008's *Journey's End*, again played by Julian Bleach. However, the actor was wearing a different make-up design. "Davros has a new face sculpt for these new [episodes]," explained Millennium FX's prosthetics effects producer Kate Walshe. "It's inkeeping with what Neill [Gorton] did before, but it's a bit more worn, a bit of gravity impacting on him." The material used inevitably decays over time. "The latex we use does not like ultraviolet light, so it does tend to break down after a while. It's a natural product, produced from rubber trees, so it doesn't survive forever," Walshe said. "We've done a few projects with Julian, so we had his life-cast already. We just needed to make sure he hadn't lost or gained any weight. Luckily, he's exactly the same shape, which saved us some time."



their cell is perfect. "But this is a space station, so the gravity should be artificial," she explains. Despite Clara's fears that they will be sucked out into space, Missy activates the airlock...

The Doctor is taken to see his old nemesis, Davros. He is shocked to see him in such a decrepit and fragile state. Davros flicks a switch, and recordings of their past confrontations are played. The Fourth Doctor's voice echoes ominously: "If someone who knew the future pointed out a child to you, and told you that child would grow up totally evil, to be a ruthless dictator who would destroy millions of innocent lives, could you then kill that child?" An alarm suddenly sounds. "It seems your friends have gone exploring," Davros says.



Missy puts her hand out of the airlock. "It's warm, isn't it? For deep space, anyway." She steps out cautiously into what seems to be a void. "We're on a planet. And that is not a space station – that is a building." The entire planet has been made invisible, but it starts to come into view for Missy and Clara. A giant city appears, surrounded by a dry desert. Missy is shocked to see that they are on Skaro, the infamous homeworld of the Daleks. The Doctor is equally horrified. "Where does an old man go to die, but with his children?" Davros says.

Missy and Clara are taken to the Daleks' control room. The Supreme Dalek is presiding over Daleks from different time periods. The TARDIS is also there. Clara warns, "You won't be able to enter or destroy it." Missy offers her services to the Daleks. She will pilot the TARDIS for them. The Supreme Dalek is unimpressed. "Maximum extermination," it orders. The Daleks open fire and Missy's body vanishes in a blast of energy.

The Doctor falls on his knees and begs Davros to save Clara. "I gave the Daleks life. I do not control them," he replies. The Doctor watches as the Daleks turn towards Clara. "See how they play with her," Davros observes. "See how they toy. They want her to run." Clara bolts for the doorway. "Exterminate!" the Daleks cry, as they fire at her. There is no trace of her body left. The Doctor is devastated. He turns to Davros. "Why have I ever let you live?" he asks. "Compassion, Doctor," Davros responds. "It has always been your greatest indulgence."



"Destroy the TARDIS!" the Dalek Supreme commands. A large energy weapon mounted on the ceiling fires at the Doctor's ship. It explodes in a shower of light.

Long ago on Skaro, the young, frightened Davros cries for help. He turns to see the Doctor behind him. "Are you going to save me?" the boy asks. "I'm going to save my friend, the only way I can," the Doctor replies, his expression determined and ice-cold. He slowly raises a Dalek gunstick and takes aim. The Doctor yells "Exterminate!"



## MORAL CODE

Showrunner Steven Moffat gave a great deal of thought to the character of Davros before he began writing *The Magician's Apprentice*. "Davros is a serious-minded individual," he stated. "He has a version of the future of the universe that makes sense to him. He's suffered massively for this, and he's sacrificed everything. He hasn't surrounded himself with great wealth and glory. He's actually not being selfish. He's dreadful – but according to his own morality, he's a hero. Davros is not doing this for his own gain." Moffat was interested in Davros' perspective: "He has as clear a moral code as the Doctor's. It's just completely the opposite to the Doctor's."



Steven Moffat

# DAVROS

## PART 7



**D**avros was frozen like a statue once more, his frail body immobilised by the Movellan virus he himself had unleashed upon his own rebellious Daleks. But while death had quickly claimed his creations, Davros' unmatched ingenuity came to his rescue.

Davros' survival chair had been designed for any eventuality. As soon as its biosensors detected the virus entering his body, it generated a cryogenic field that slowed his life functions to near zero. This also halted the progression of the virus. The chair's artificial intelligence unit was automatically activated at the same time. It moved Davros to the nearby escape pod and sent it blasting into space mere seconds before the Terran prison ship exploded.

For weeks, Davros drifted in space, overlooked and forgotten. His chair fed his body a calibrated stream of antimicrobial agents to combat the virus. When it was completely eradicated, Davros was revived, weak but alive. He knew that if he had any chance of survival, he would need new allies who could provide him with resources and secrecy.

Fortunately, there was a galaxy-wide famine taking place at the time. One of the main figures profiting from the crisis was Madame Kara, an industrialist who was selling synthetic food. Davros had plenty of experience in that field – he had saved millions of Kaleds from starvation on Skaro. He contacted Kara on a trans-warp waveband, sending her an anonymous schematic for a newer, cheaper food substitute. Kara

responded immediately, providing him with transport to her headquarters on the planet Necros. Her initial shock at Davros' identity was soon mollified when she realised how much money his genius could make for her.

Kara reminded Davros of the women he had encountered on Skaro centuries ago, before his body had been shattered in the thousand-year war. There had been many like her among the wealthy Kaled elite – her superficial elegance did little to conceal her greed. Her sense of misplaced entitlement was almost palpable. Kara believed herself to be an example of superior breeding, which Davros found laughably absurd. He knew that the only true measure of superiority came from intelligence.

Davros was soon established as 'The Great Healer' at Tranquil Repose, a centre that stored wealthy men and women in cryogenic suspension. Its chief functionary was Jobel, a preening fool whose vanity was matched only by his insecurity. His ridiculous toupee and pathetic pursuit of much younger women exposed his obvious fear of mortality. Kara and Jobel were a pair of weak-willed idiots, and perfect pawns for his plans. Davros used the bodies at Tranquil Repose as genetic fodder to create a new species of Dalek – one that would be completely loyal to him.

The image of the Doctor pointing a weapon at his head was seared into Davros' mind, burned there in vivid detail. It had been a deeply humiliating and infuriating experience. Davros swore never to be so vulnerable again. He armed his chair with an ionic generator that could send bolts of lethal energy through his fingertips or artificial eye, and added a powerful anti-gravity device to its base. He also crafted a lifelike facsimile of himself, one that he could operate from afar like a puppet. It would serve as the perfect decoy for any would-be assassins.

Davros formulated his plan for revenge on the Doctor. He would capture him and place him inside a transparent Dalek-shaped shell. Once he had obtained a full biological read-out of his enemy, he would put the Doctor through the same genetic alteration process as the humans on Tranquil Repose. He would observe the Doctor's slow transformation into a Dalek. As he changed day by day, the Doctor's arrogance would be stripped away, his identity shredded into a thousand pieces, until nothing was left except blind obedience. It would be a deeply pleasurable experience to watch.

Professor Arthur Stengos was an important piece needed for his elaborate game. Davros had researched the Doctor's movements and was aware that Stengos was a good friend of his. When Stengos fell into a coma, Davros instructed Kara to bribe some medical officials and have him brought to Necros. Stengos would be the perfect bait to lure the Doctor into his trap. But Stengos also served another purpose: Davros used his body as a test subject to make sure that the process he planned for the Doctor would be successful.

Davros wished to toy with the Doctor, crushing his irritating confidence. He had a bust of the Doctor carved and prominently placed near the entrance of Tranquil Repose. The Doctor was stunned to discover what appeared to be his own

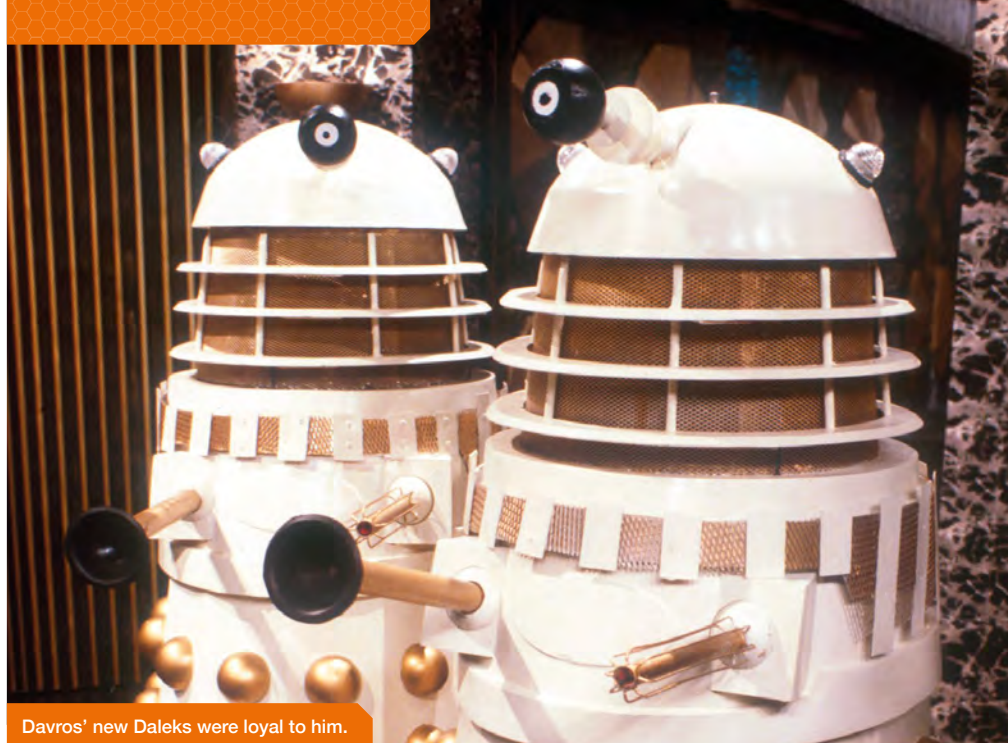

Davros' new Daleks were loyal to him.

grave. Davros was delighted to see his enemy so badly shaken – the Time Lord had finally tasted his own mortality.

The Doctor was soon at Davros' mercy. The plan had been perfect. Davros had anticipated every factor except one: he had underestimated Kara's greed. The sudden arrival of Orcini, an assassin hired by Kara, coincided with the Doctor's arrival, causing difficulties. And then a minor functionary at Tranquil Repose delivered the worst betrayal of all: he contacted the remnants of the Dalek forces and alerted them to his location. Davros' Daleks were outnumbered by the invading Daleks and were quickly destroyed.

Davros once again found himself surrounded by his own ungrateful children, with his most hated enemy watching. "You are to be taken back to Skaro to stand trial for crimes against the Daleks," the lead Dalek stated. The concept of being judged by his own creations incensed Davros, but he had no other options left. The Doctor watched him leave, his arrogance fully restored.

But as Davros glided through the catacombs beneath Tranquil Repose, he was already planning his next move. No Dalek could ever match his cunning. He would find a way to not only survive, but be victorious. He had conquered Skaro once. He knew he could do it again...



The Doctor, once again, foiled Davros' plans.



Davros made a deal with the devious Madame Kara.

# BASE SECTION

## INTERNAL SUPPORT STRUCTURE

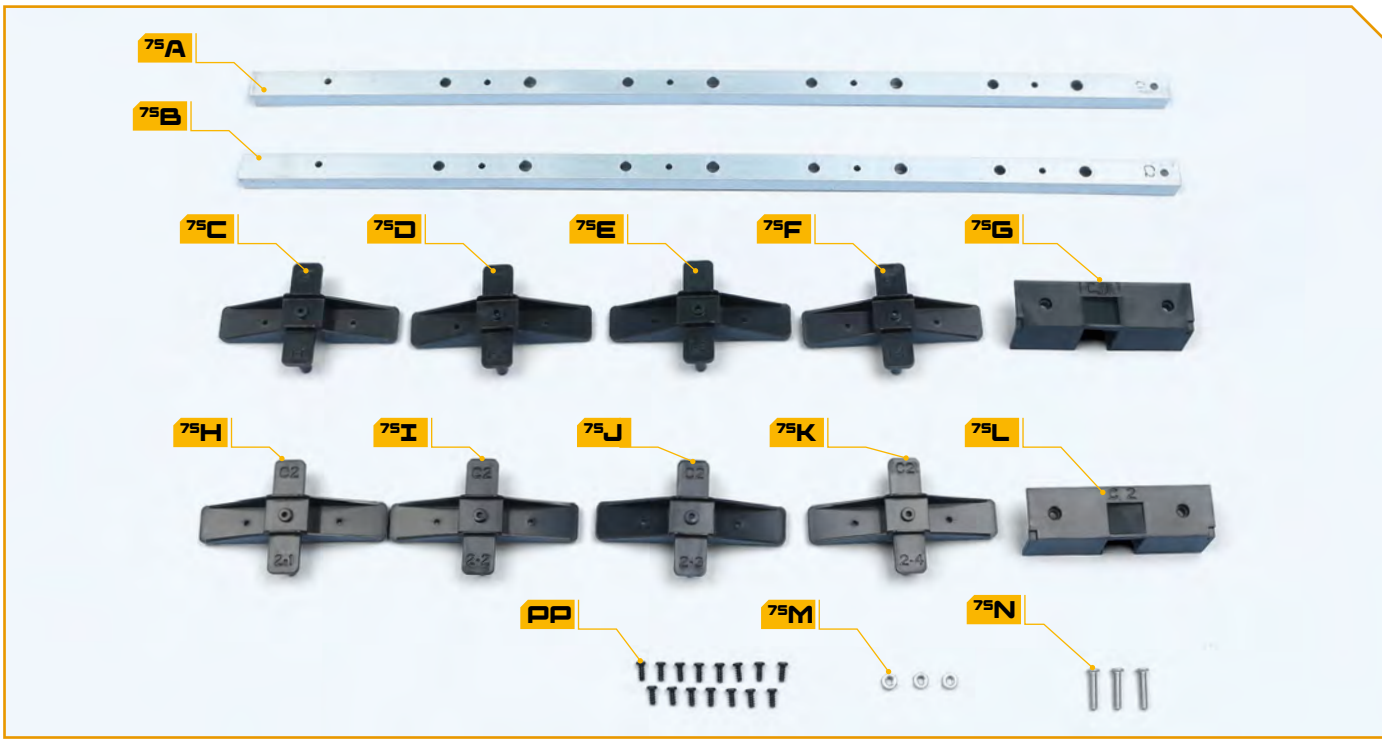

### COMPONENTS OF ISSUE 75

- 75A** SIDE SUPPORT (labelled C1)
- 75B** SIDE SUPPORT (labelled C2)
- 75C** SKIRT FIXING PART (labelled C1/1-1)
- 75D** SKIRT FIXING PART (labelled C1/1-2)
- 75E** SKIRT FIXING PART (labelled C1/1-3)
- 75F** SKIRT FIXING PART (labelled C1/1-4)
- 75G** SIDE SUPPORT TOP JOINT (labelled C1)
- 75H** SKIRT FIXING PART (labelled C2/2-1)
- 75I** SKIRT FIXING PART (labelled C2/2-2)
- 75J** SKIRT FIXING PART (labelled C2/2-3)
- 75K** SKIRT FIXING PART (labelled C2/2-4)
- 75L** SIDE SUPPORT TOP JOINT (labelled C2)
- 75M** NUTS (x 3, 1 spare)
- 75N** BOLTS (x 3, 1 spare)
- PP** FIFTEEN 2.6 X 6MM PB SCREWS (1 spare)

### #75-01

Take the side support **75A** (marked C1) and the four skirt fixing parts **75C**, **75D**, **75E** and **75F**. Position them as shown, so that the raised screw holes on the skirt fixing parts fit into the large holes in part **75A**. Note that the label C1 on part **75A** is at the top. Check the order and orientation of the parts carefully. Fix each fixing part in place on the back of the side support **75A** with a **PP** screw.

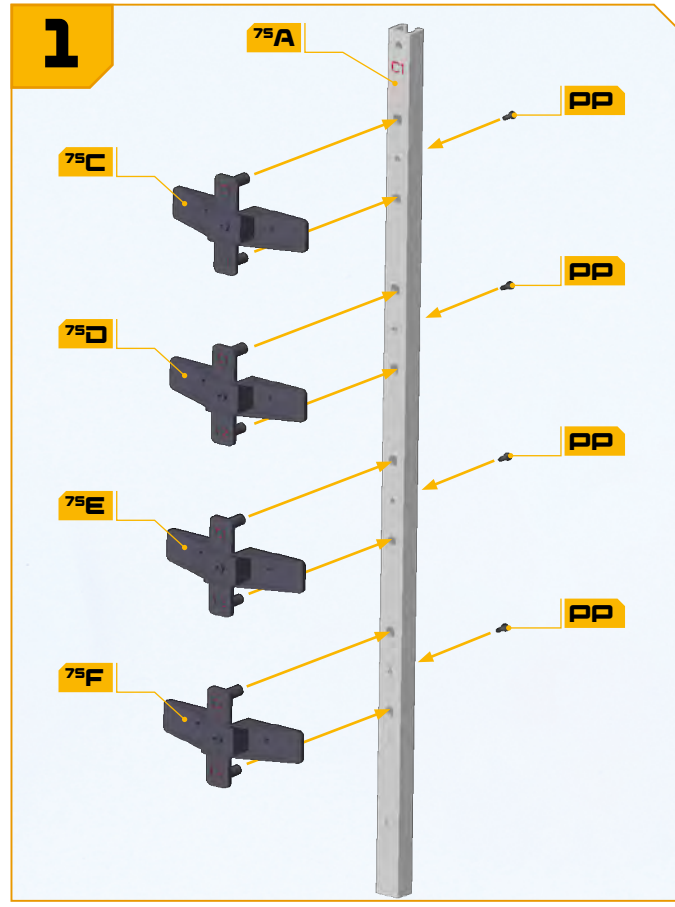

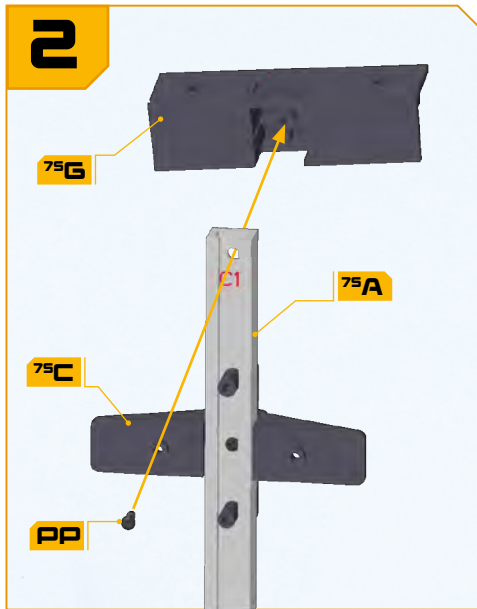

### #75-02

Take the side support top joint (labelled C1) **75G** and fit the top of part **75A** into the recess so that screw holes are aligned. Note the orientation of the parts with the channel in part **75A** and the raised screw sockets in part **75C**, **75D**, **75E** and **75F** are facing forwards. Fix in place with a **PP** screw.

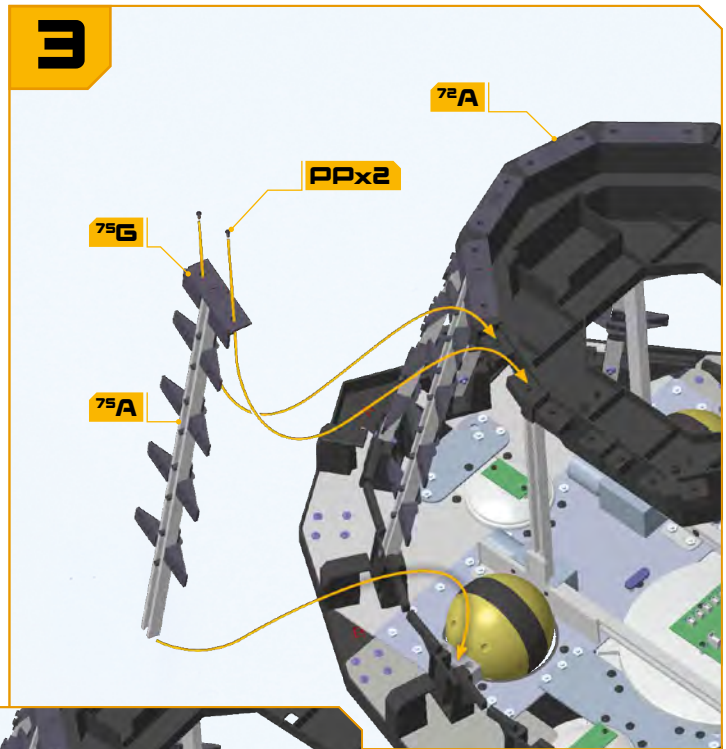

### #75-03

Fit the base of the side support **75A** into the channel in the next skirt support, next to the front left wheel. Fit the top joint **75G** into the corresponding shape marked C1 in the side of the chest support **72A**. Fix in place with two **PP** screws (inset).



### #75-04

Fit a bolt **75N** through the screw holes in the skirt holder and part **75A** (yellow arrow). Fit a nut **75M** on the end of the bolt to hold it in place (red arrow). Use the spanner **38F** to help tighten the nut if necessary.

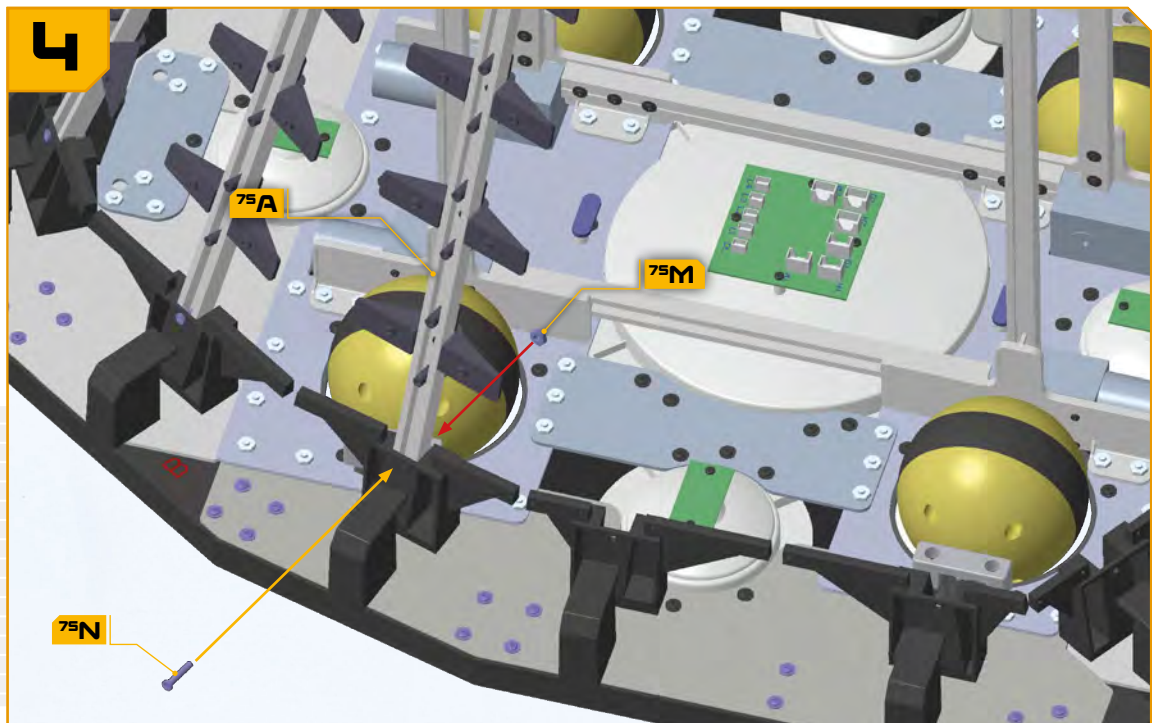

**#75-05**

Take the side support **75B** (marked C2) and the four skirt fixing parts **75H**, **75I**, **75J** and **75K**. Position them as shown, so that raised screw holes on the skirt fixing parts fit into large holes in part **75B**. Note that the label C2 on part **75B** is at the top. Check the order and orientation of the parts carefully. Fix each fixing part in place from the back of the side support **75B** with a **PP** screw.

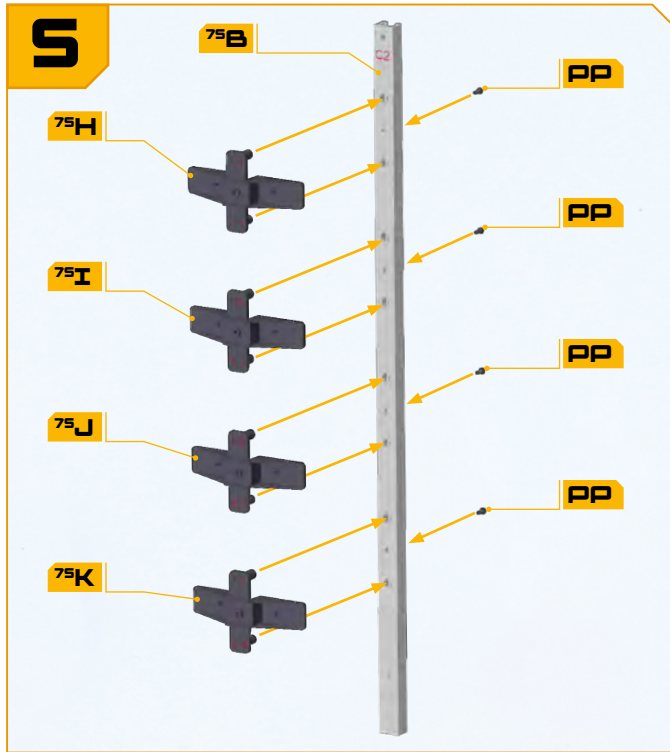

**#74-06**

Take the side support top joint (labelled C2) **75L** and fit the top of part **75B** into the recess so that screw holes are aligned. Note the orientation of the parts with the channel in part **75B** and the raised screw sockets in parts **75H**, **75I**, **75J** and **75K** that are facing forwards. Fix in place with a **PP** screw.

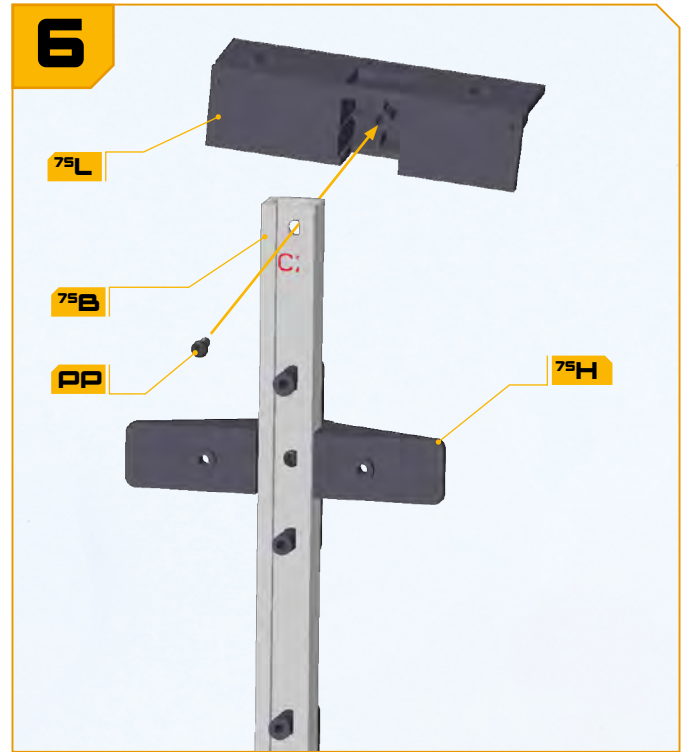

**#75-07**

Fit the base of the side support **75B** into the channel on the inner side of the next skirt support beside the front right wheel. Fit the top joint **75L** into the corresponding shape in the side of the chest support **72A**, which is marked C2. Fix in place with two **PP** screws.

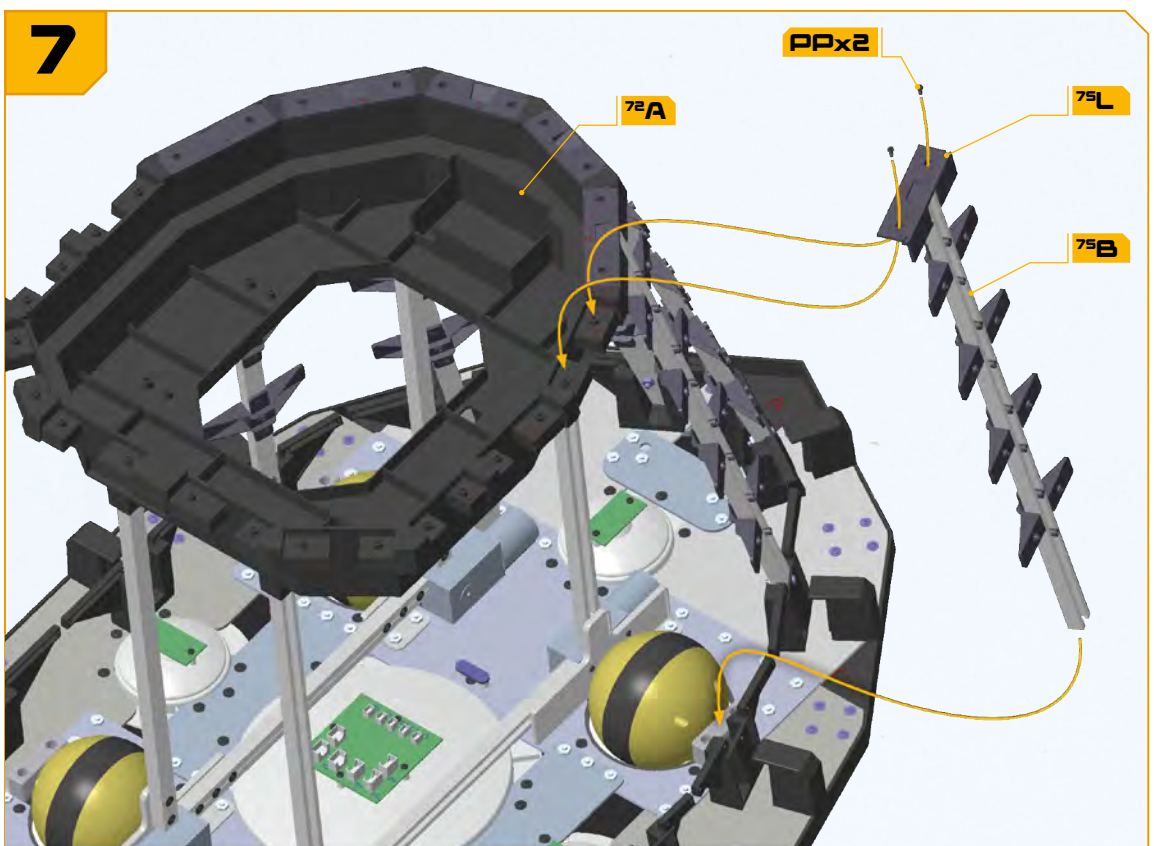

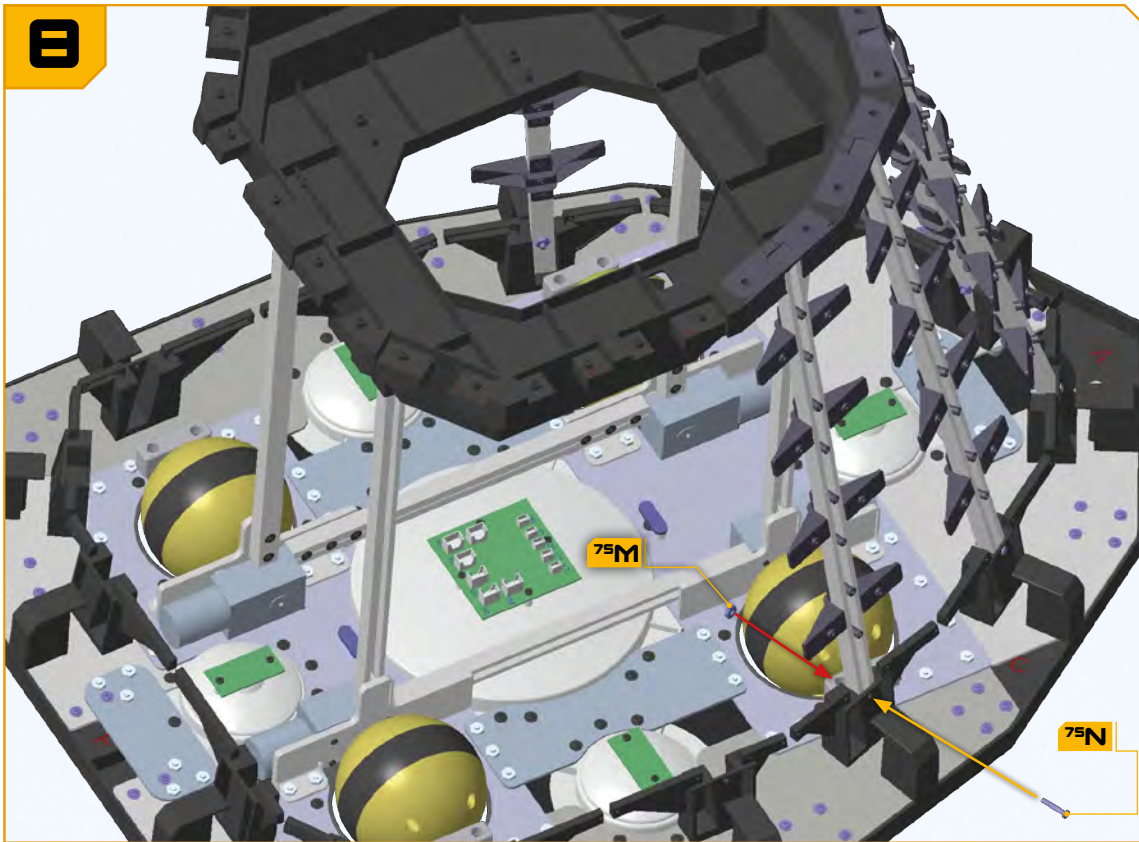
**8****#75-08**

Fit a bolt **75N** through the screw holes in the skirt support and part **75B** (yellow arrow). Fit a nut **75M** on the end of the bolt to hold it in place (red arrow). Use the spanner **38F** to help tighten the nut if necessary.

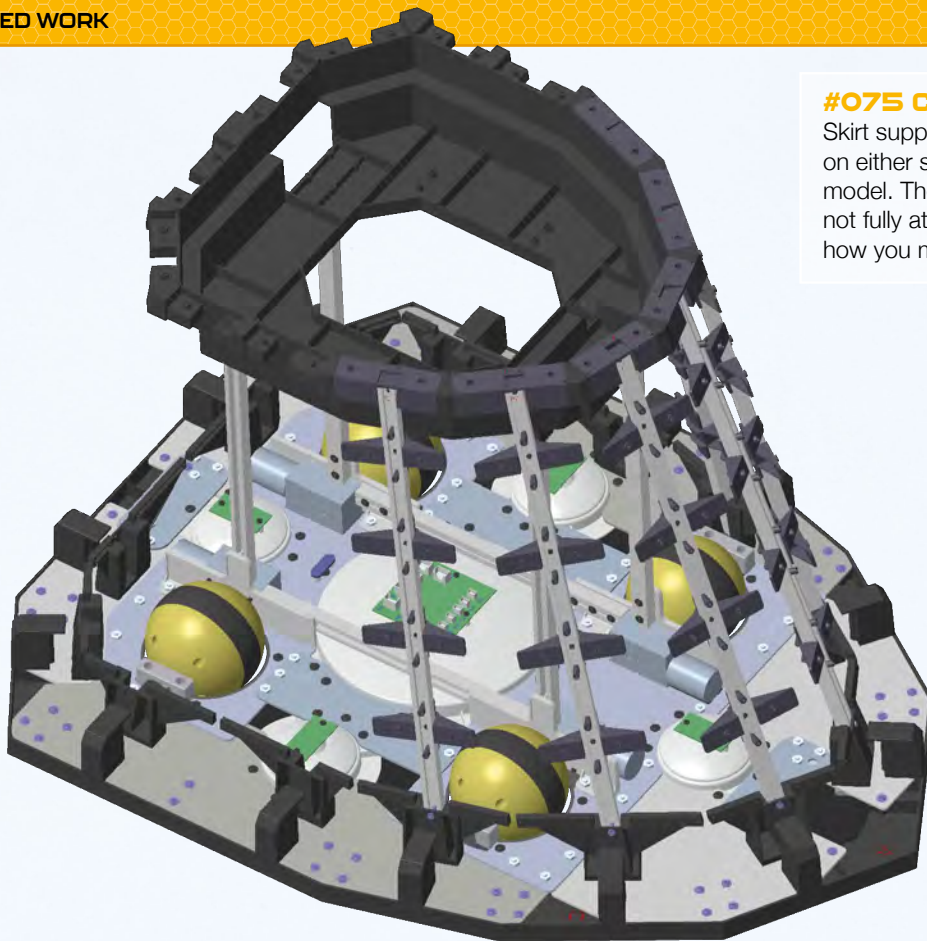
**COMPLETED WORK****#075 COMPLETED WORK**

Skirt supports have been fitted on either side of the base of your model. The chest support is still not fully attached, so be careful how you move the model.

# THE DALEK

COMING IN  
ISSUE 76

## BUILD PART 76

Continue the skirt section in issue 76 with further side supports, skirt fixings, joints and all the required nuts and bolts.



## THE TIME VORTEX



The Daleks have battled humanity across the millennia, invading the Earth several times, but they have always been thwarted.

## ADVENTURES IN TIME AND SPACE



The Doctor and his friends are separated and must escape London before the Daleks firebomb the city in *Day of Reckoning*.

Every week at your newsagent! Visit [hachettepartworks.com/Dalek](http://hachettepartworks.com/Dalek)